

PLAN REVIEW TABLE

Models covered: 65" 55" 43"

**DO NOT
DISCARD**

UNPACKING & ASSEMBLY

INSTRUCTIONS

Contains important safety and assembly details

For Volanti Displays Plan Review Tables with displays 65", 55" or 43"

Contents

1. **Introduction**
 - 1.1. Product description
 - 1.2. Important safety information
2. **Package contents**
 - 2.1. Table base box
 - 2.2. Touchscreen display box
 - 2.3. Accessory boxes (if applicable)
3. **Tools required for assembly**
 - 3.1. List of necessary tools (if any)
4. **Unpacking instructions**
 - 4.1. Safety precautions during unpacking
 - 4.2. Unpacking the table base
 - 4.2.1. Step-by-step instructions with illustrations
 - 4.3. Unpacking the touchscreen display
 - 4.3.1. Step-by-step instructions with illustrations
 - 4.4. Unpacking accessories (if applicable)
 - 4.4.1. Step-by-step instructions with illustrations
5. **Assembly instructions**
 - 5.1. Attaching the touchscreen display to the table base
 - 5.1.1. Step-by-step instructions with illustrations
 - 5.2. Safety precautions during assembly
 - 5.3. Assembling and attaching accessories (if applicable)
 - 5.4. Step-by-step instructions for each accessory with illustrations
 - 5.5. Safety precautions during accessory assembly
6. **FCC compliance information**
 - 6.1. FCC
7. **EU compliance information**
 - 7.1. CE marking
 - 7.2. WEEE directive (Waste Electrical and Electronic Equipment)
 - 7.3. RoHS directive (Restriction of Hazardous Substances)
8. **Manufacturer's contact information**
 - 8.1. Address
 - 8.2. Phone number
 - 8.3. Email address
 - 8.4. Website

1. Introduction



Pictured: The Volanti Display Digital Plan Review Table with optional accessories installed together with user items such as the laptop and tumbler.

1.1 Product Description

The Digital Plan Review Table is a professional-grade solution specifically designed for use in business settings, such as offices, conference rooms, and other organization plan review locations. This advanced product features a large, high-resolution touchscreen display mounted on a sturdy, wheeled base with electric height and tilt adjustment, making it ideal for plan review, collaborative discussions, presentations, and meetings.

Engineered with businesses in mind, the Digital Plan Review Table offers a range of features to enhance productivity and facilitate seamless communication. The touchscreen display supports multi-touch input, allowing for panel and zoom as well as other multi-touch functions depending on the software. The wheeled base provides smooth mobility, ensuring that the table can be easily moved between different locations within your workspace as needed.

A range of optional accessories can be attached to the Digital Plan Review Table to further tailor it to your specific business requirements. These accessories may include a keyboard tray, one

or more side monitors, a laptop tray, a PC and docking station, a webcam, a power cable reel, a backup battery, and more.

1.2 Important safety information

To ensure the safe and proper use of the Digital Plan Review Table in a business setting, please read and adhere to the following important safety instructions:

- Always use the table on a flat, stable surface to prevent tipping or sliding. Ensure that the table is positioned so that it does not obstruct walkways or emergency exits.
- Do not exceed the maximum weight capacity of the table or any attached accessories to prevent damage or instability.
- Exercise caution when moving the table, particularly on uneven surfaces or through doorways. Always push the table using the provided handles and avoid pulling on the touchscreen display glass.
- Keep the table away from water, heat sources, and direct sunlight to prevent damage to the electronic components. Ensure that the table is used in a temperature-controlled environment suitable for electronic devices.
- Only use the power cables and adapters provided with the table. Ensure that the power outlet is properly grounded and matches the voltage requirements of the table. Do not overload power outlets or use extension cords that are not rated for the table's power requirements.
- Do not attempt to open or modify the table's electronic components, including the touchscreen display and control box. Any repairs or modifications should only be performed by authorized service personnel to ensure the product's integrity and compliance with business regulations.
- Train all employees who will be using the Digital Plan Review Table on its proper use and safety guidelines. Ensure that the table and its accessories are kept out of reach of unauthorized personnel when not in use.
- When adjusting the height or tilt of the table, ensure that there are no obstacles or people in the way to prevent pinching or crushing hazards. Establish a clear protocol for adjusting the table to minimize the risk of accidents in the workplace.
- Regularly inspect the table and its components for any signs of damage or wear. Remove the table from service if any parts are damaged or malfunctioning, and contact the manufacturer or authorized service provider for repairs.
- Always unplug the table from the power outlet before cleaning or performing any maintenance tasks. Follow the manufacturer's recommended cleaning and maintenance procedures to ensure the longevity and optimal performance of the product.

By adhering to these safety guidelines, you can ensure that your Digital Plan Review Table is used safely and effectively in your business environment, promoting a productive and secure workplace.

2. Package Contents

The Volanti Plan Review Table is usually shipped on a pallet in two main boxes:

- Large square box
 - Table Base
 - Accessories, as ordered
- Large rectangular box
 - Touchscreen display

Depending on the details of the order and the delivery, the packing may vary, for example with multiple plan review tables the tables may be consolidated onto one pallet and the displays on another.

3. Tools Required for Assembly

During the unpacking and assembly, you will need:

- Knife, to cut open packing material only.
- Philips screwdrivers for M6 and M4 size screws. These are used for securing the monitor and the height & tilt paddles.

Optional Accessories

Each accessory will have its own assembly instructions.

4. Unpacking Instructions

Before unpacking - Inspect The Delivery For Signs of Damage

If there is damage, take photos and have the delivery company acknowledge the damage

The Volanti Plan Review Table is shipped on a pallet and may be wrapped in black or clear plastic. Remove and discard the wrapping, but keep any freight or shipping documentation.

There are two boxes on the pallet secured by bands:

Cut the bands securing the larger square box.

Using two people, lift the large square box up and away from the pallet to uncover the table base and any accessories.



Remove any accessory boxes packed around the base.

Remove the wing-nuts on the front of the wood box and then remove the front panel. This will allow the table to be rolled out - **use two people as the table base is heavy.**

CAUTION - the table base is heavy, use two people and do not allow it to drop off the edge of the pallet as this can damage the wheels.

For the assembly step that follows you will need access to power.



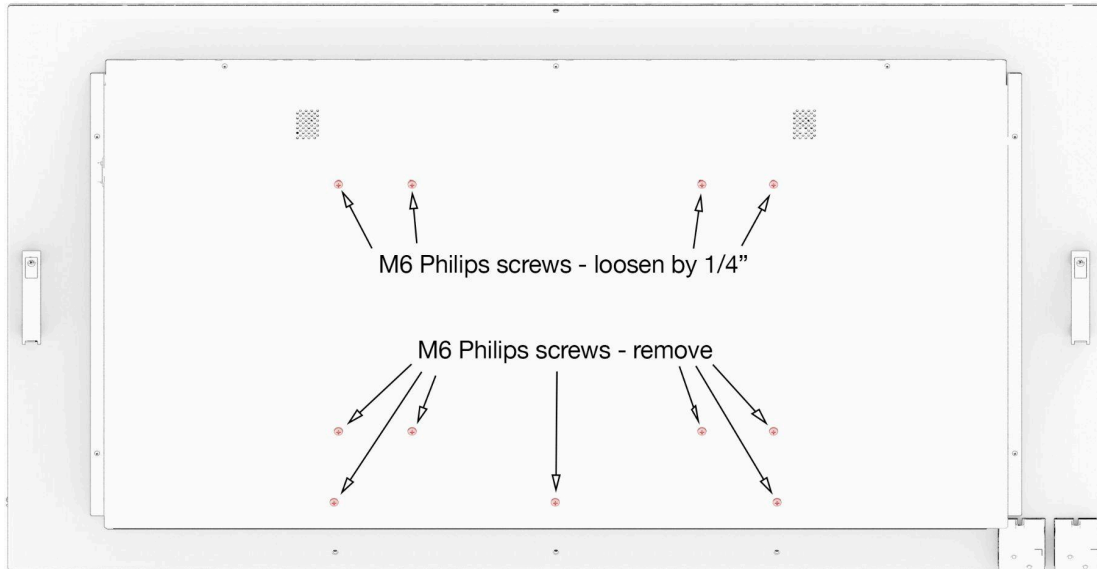
5. Assembly Instructions

PREPARING THE TABLE BASE

- Locate the table base mains power cord and connect to an outlet, this is to enable adjustment of the monitor mounting plate. After connecting power, move to the next step.
- Locate the Height and Tilt adjustment paddles. They will be in a plastic bag taped to the side of the table leg. In a later step these will be fixed to the touchscreen display, for now, they will just be used to adjust the display mounting plate position to make the process easier.
- Using the paddles, adjust the height and tilt to a convenient height and to a nearly horizontal position.



PREPARING THE DISPLAY - 65"



- Loosen the four upper M6 Philips screws so they are approx $\frac{1}{4}$ " (8mm) out. These are used to hook the display onto the mounting plate.
- Remove the seven lower M6 Philips screws (marked in red if you are viewing this in color) but do not discard them. These will be used to secure the display on the mounting plate when it is in place.

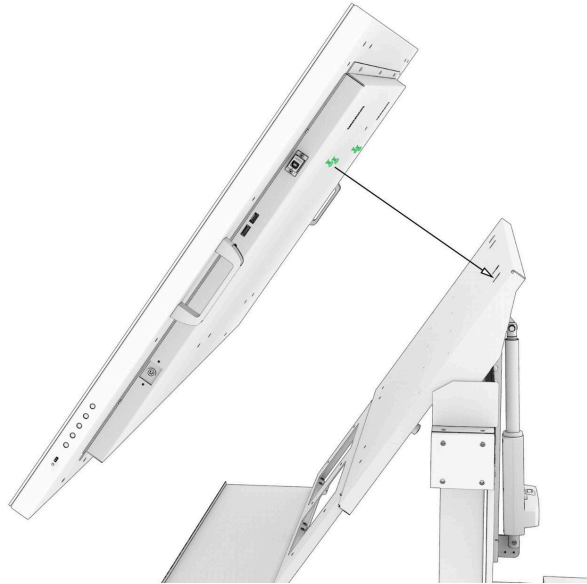
IMPORTANT NOTE - 55"

If your delivery includes a keyboard tray, the three screws on the bottom row will be in a bracket, it is important to remove them so the display can lay flat on the mounting plate. They should be reinstalled after the display is in position.

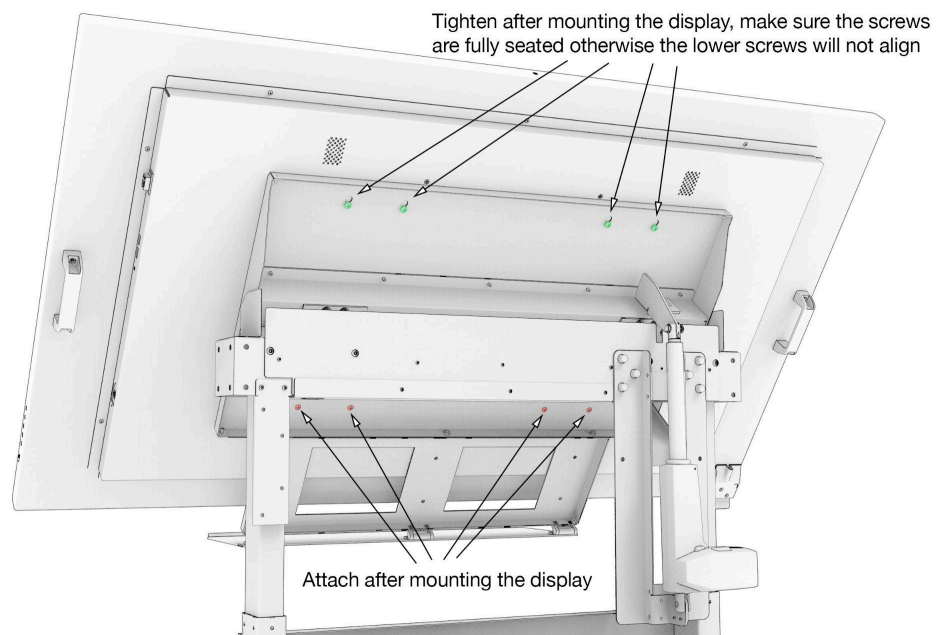


Image shows the upper screws approx 1.4" (8mm) out so they can pass through and hook onto the keyhole-shaped holes on the table mounting plate.

MOUNTING THE DISPLAY ONTO THE TABLE BASE

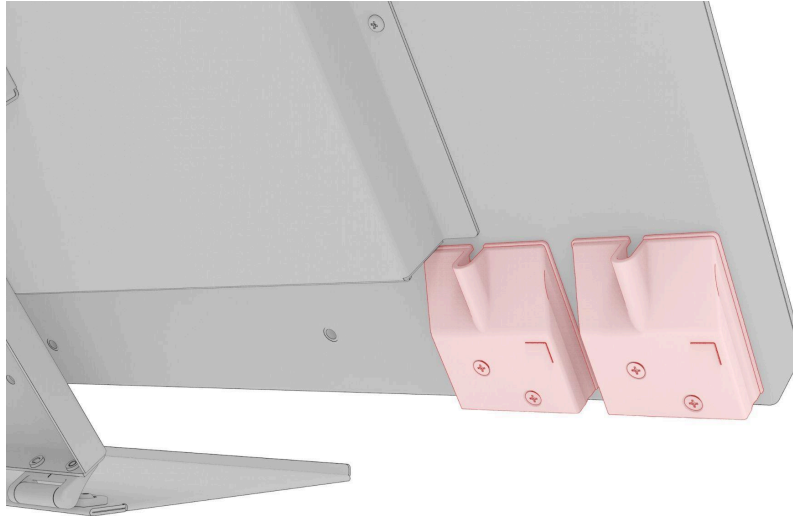


- Using two people lift the display onto the mounting plate aligning the loosened screws with the keyhole-shaped holes in the upper side of the mounting plate.
- The lower screws can now be returned through the mounting plate
- Tighten the upper and lower M6 mounting screws.

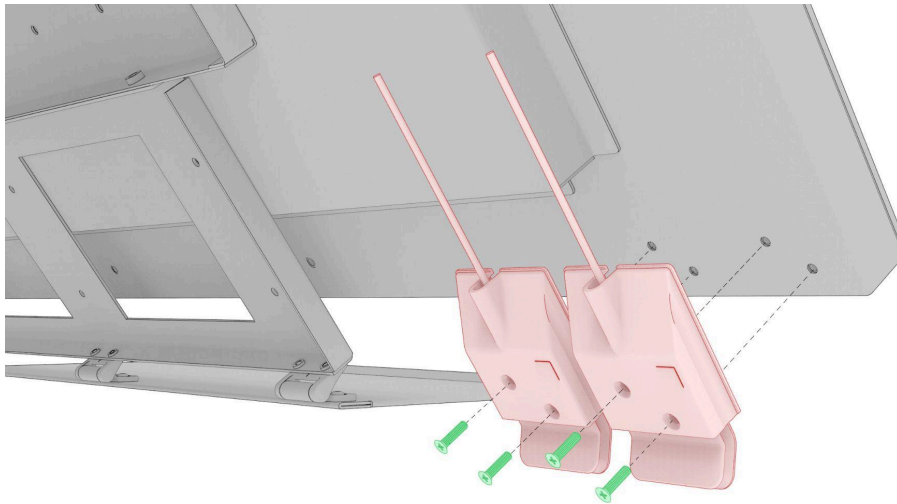


ATTACHING THE HEIGHT & TILT ADJUST PADDLES

The covers of the height and tilt adjustment paddles are already attached to the lower edge of the back of the touchscreen display as shown. Unscrew these, keeping all parts.



Then, together with the paddle parts in the plastic bag, assemble with the covers, the screws are M4x25mm (not longer or shorter), and attach to the display as shown.



You can have either Height or Tilt as the nearest or furthest according to your preference.

ACCESSORIES ASSEMBLY

The Accessories assembly instructions are shown in separate documents.

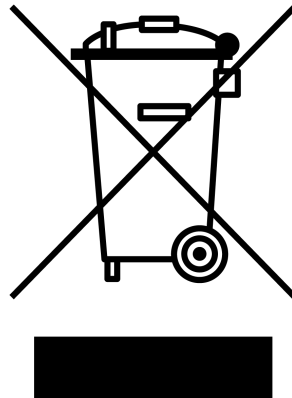
6. FCC

See the Plan Review Table Usage Instructions for the FCC compliance statement.

7. EU Compliance Information

See the Plan Review Table Usage Instructions for the CE compliance statement.

Waste Electrical and Electronic Equipment (WEEE) Disposal Information



This product is classified as professional electrical and electronic equipment and should not be disposed of with regular waste. Proper disposal of this equipment helps prevent potential negative consequences for the environment and human health.

As the manufacturer, we are committed to reducing the environmental impact of our products. However, as we are supplying this product from the United States, we are unable to directly assist with its disposal in other countries.

It is the responsibility of the user to dispose of this equipment in accordance with local laws and regulations. We recommend contacting your local authorities or professional waste management services for guidance on the proper disposal methods in your area.

When disposing of this equipment, please consider the following:

1. Arrange for separate collection and recycling of the equipment through a designated waste management company or a local collection point.

2. If applicable, remove any batteries and dispose of them separately according to local regulations.
3. Check with your local authorities for any specific requirements or guidelines for disposing of professional electrical and electronic equipment in your region.
4. Keep in mind that proper disposal of this equipment can help conserve natural resources and protect the environment.

If you have any questions about the disposal of this product or the environmental impact of waste electrical and electronic equipment, please contact your local authorities or professional waste management services for further assistance.

The manufacturer's contact information is shown in section 7.

RoHS directive (Restriction of Hazardous Substances)

Restriction of Hazardous Substances (RoHS) Information

This product is designed for professional use and is sold exclusively to businesses. As such, it may not comply with all the restrictions on hazardous substances as specified in the European Union's Directive 2011/65/EU on the Restriction of the Use of Certain Hazardous Substances in Electrical and Electronic Equipment (RoHS).

The RoHS directive restricts the use of the following hazardous substances in electrical and electronic equipment:

1. Lead (Pb)
2. Mercury (Hg)
3. Cadmium (Cd)
4. Hexavalent Chromium (Cr6+)
5. Polybrominated Biphenyls (PBB)
6. Polybrominated Diphenyl Ethers (PBDE)
7. Bis(2-Ethylhexyl) phthalate (DEHP)
8. Butyl benzyl phthalate (BBP)
9. Dibutyl phthalate (DBP)
10. Diisobutyl phthalate (DIBP)



While we strive to minimize the use of hazardous substances in our products, this product may contain some of the substances listed above. Business users are responsible for ensuring that the use and eventual disposal of this product comply with all applicable laws and regulations.

If you have any questions about the presence of hazardous substances in this product or the environmental impact of its use and disposal, please contact [include manufacturer's contact information].

8. Manufacturer's Contact Information

7.1 Address

Volanti Displays
18440 Technology Drive
Morgan Hill
California, 95037
USA

7.2 Phone Number

+1.408.500.3500

7.3 Email Address

sales@volantidisplays.com

7.4 Website

www.volantidisplays.com

Note

The product may be changed or variations introduced that are not reflected in these instructions. Always review the product; if something doesn't make sense, please contact us. We appreciate any comments or suggestions for improvement.